

2-2N: 220-240V - 50/60 Hz - 7.6 kW  
 2N: 380-415V - 50/60 Hz - 7.6 kW  
 1N: 220-240V - 50/60 Hz - 7.6 kW  
 1N: 220-240V - 50/60 Hz - 3.7 kW

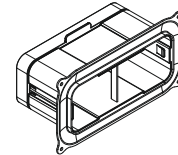

A 1x

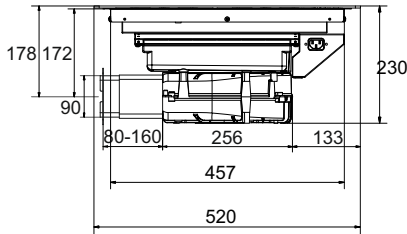
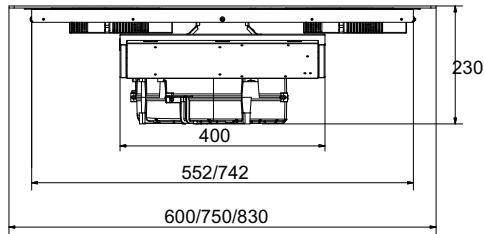
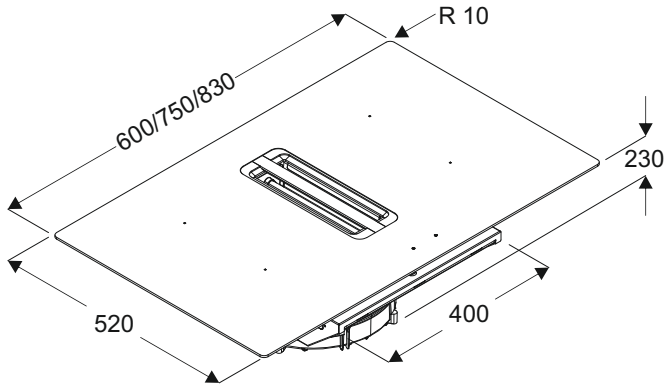
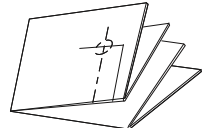

B 1x



C 1x



D 4x

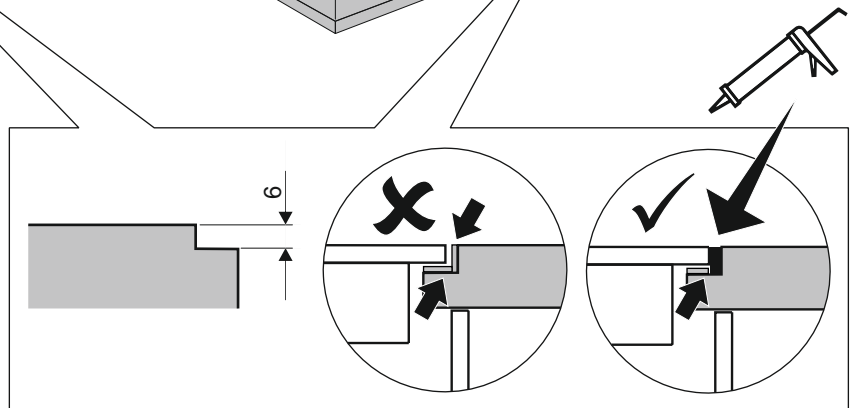
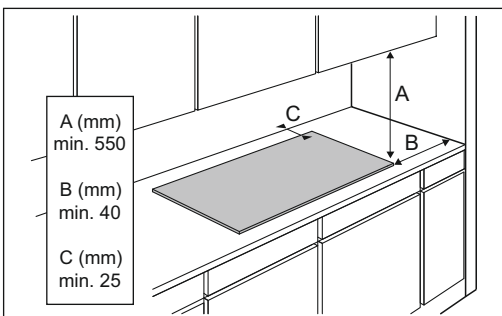
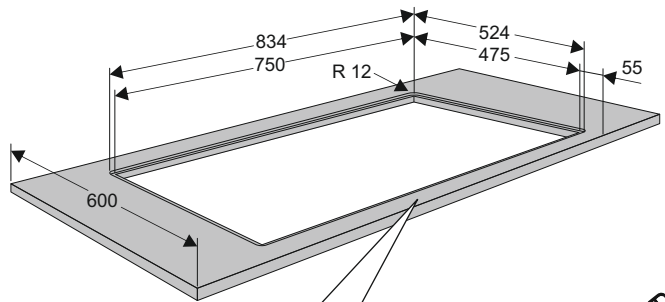
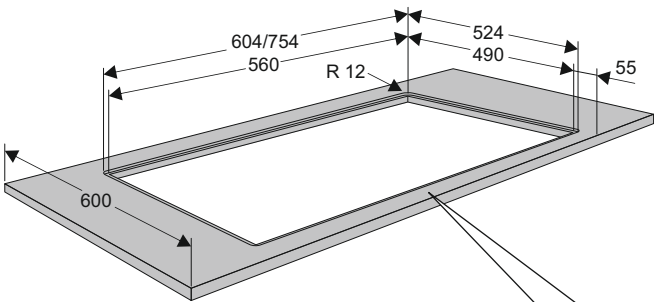
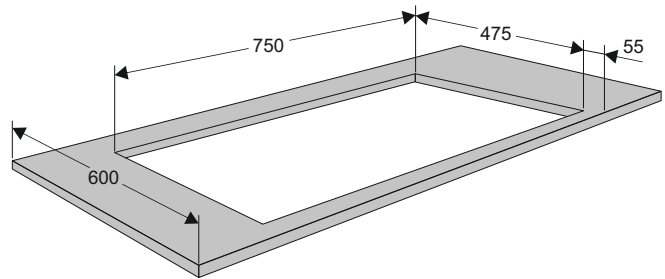
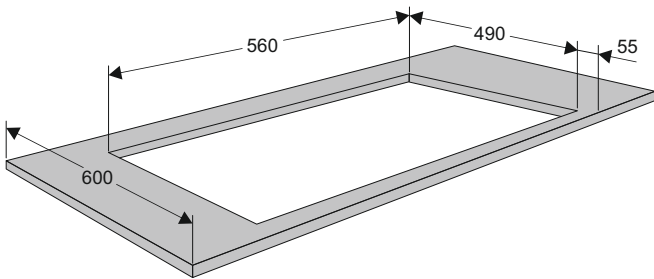

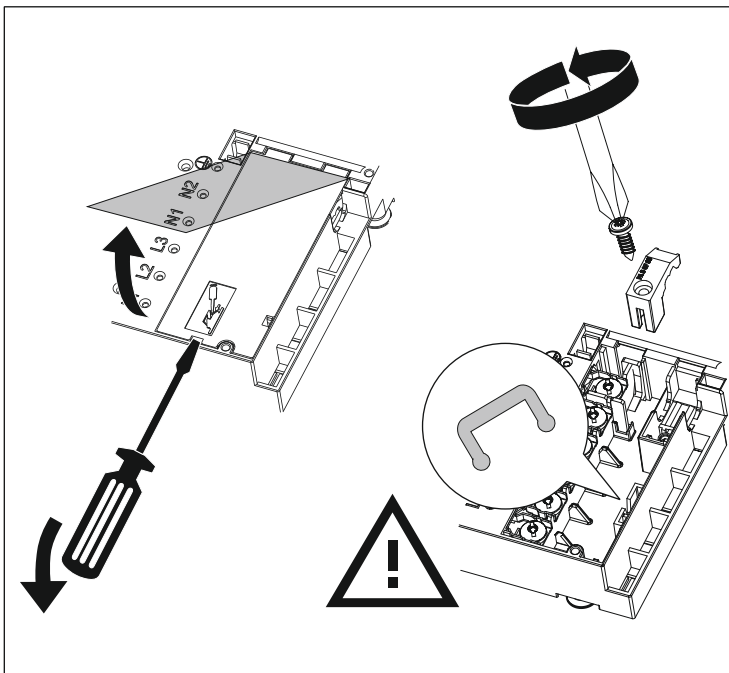
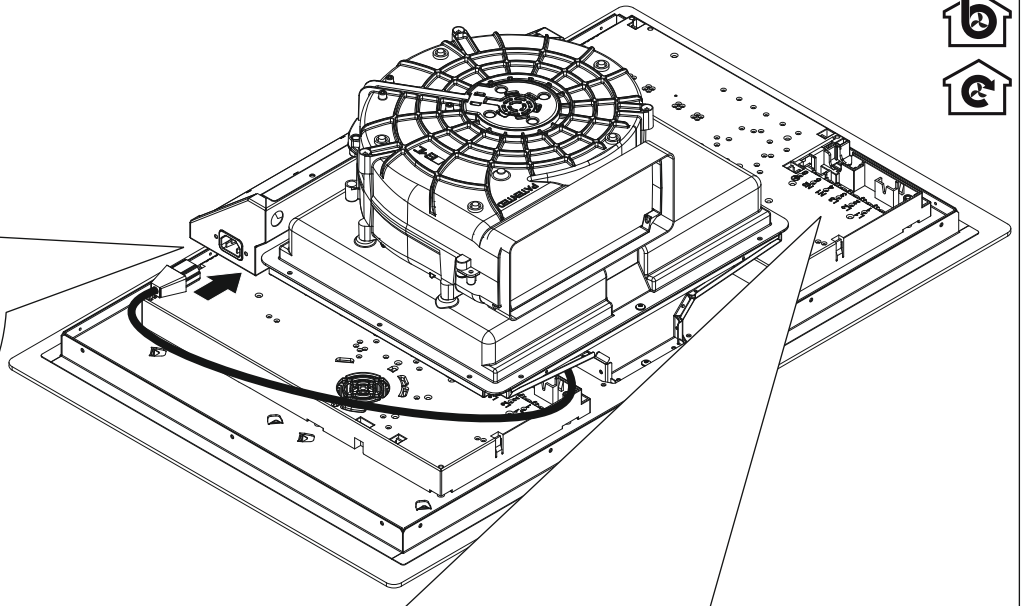
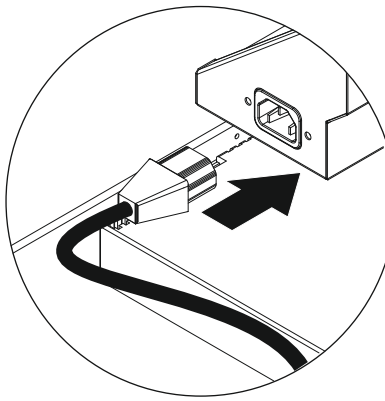

2N 380-415V 50/60Hz - 2x 16A ≡

2 fase - 1 nul  
2 phases - 1 neutral  
2 Phasen - 1 Nullanschluss  
2 phases et 1 neutre

Aderdoorsnede  
Aderquerschnitt  
Cross sectional area  
Fil diamètre

4x2,5 mm<sup>2</sup>

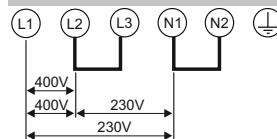

1N 220-240V 50/60Hz - 1x 32A ≡

1 fase - 1 nul  
1 phase - 1 neutral  
1 Phase - 1 Nullanschluss  
1 phase et 1 neutre

Aderdoorsnede  
Aderquerschnitt  
Cross sectional area  
Fil diamètre

3x4 mm<sup>2</sup>

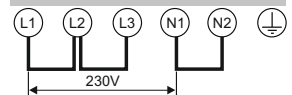

1N 220-240V 50/60Hz - 1x 16A ≡

1 fase - 1 nul  
1 phase - 1 neutral  
1 Phase - 1 Nullanschluss  
1 phase et 1 neutre

Aderdoorsnede  
Aderquerschnitt  
Cross sectional area  
Fil diamètre

3x2,5 mm<sup>2</sup>

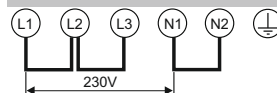

⚠ Max 3720W



2-2N 230V 50Hz - 2x 16A ≡

2 fase - 2 nullen  
2 phases - 2 neutral  
2 Phasen - 2 Nullanschlüsse  
2 phases et 2 neutres

Aderdoorsnede  
Aderquerschnitt  
Cross sectional area  
Fil diamètre

5x2,5 mm<sup>2</sup>

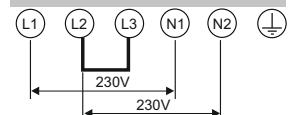

⚠ only NL/alleen NL

1



C 1x

2x

2x

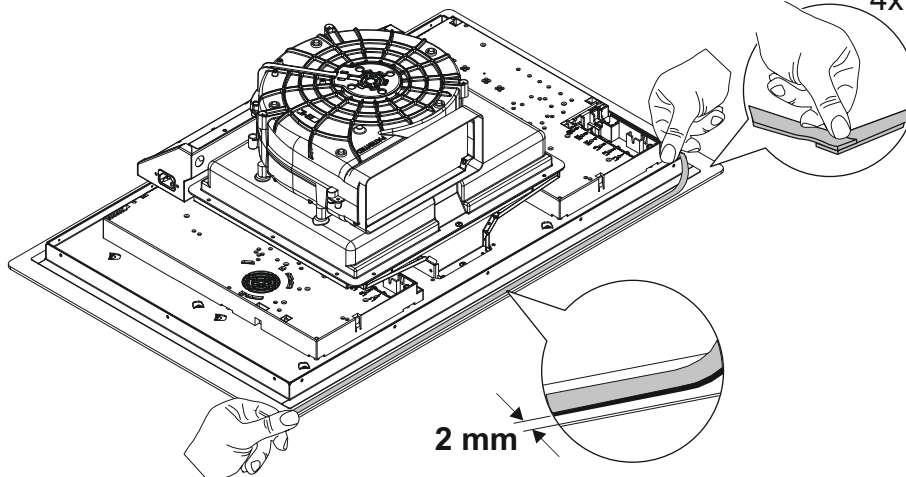

2 mm

4x

2

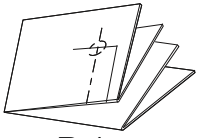

B 1x

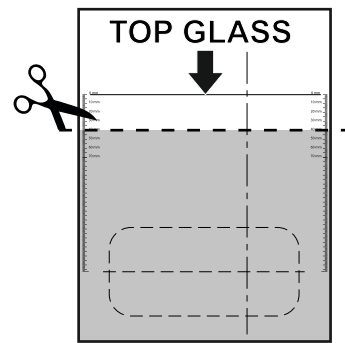
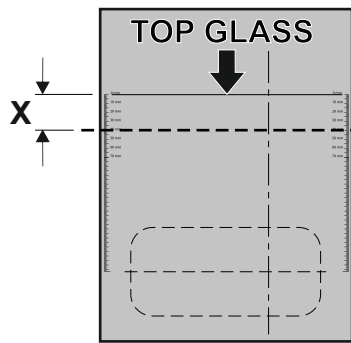
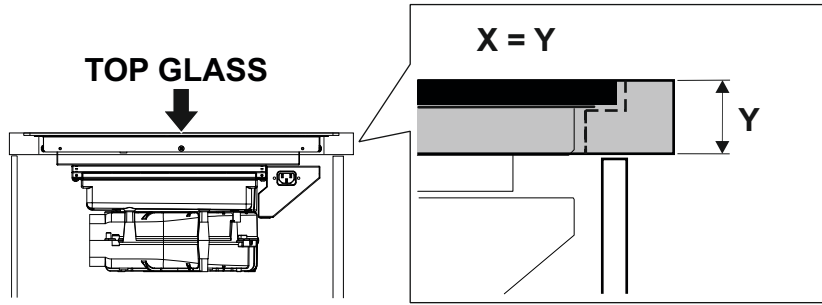
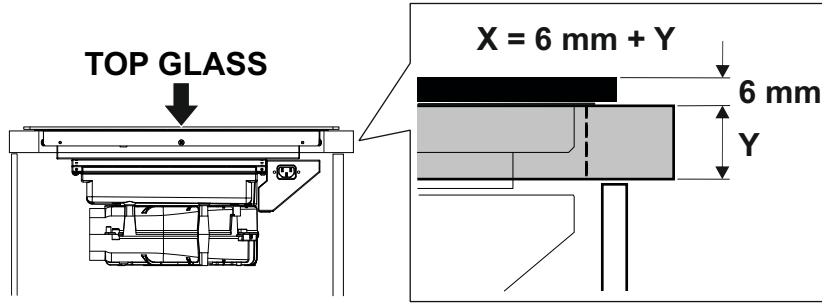

3

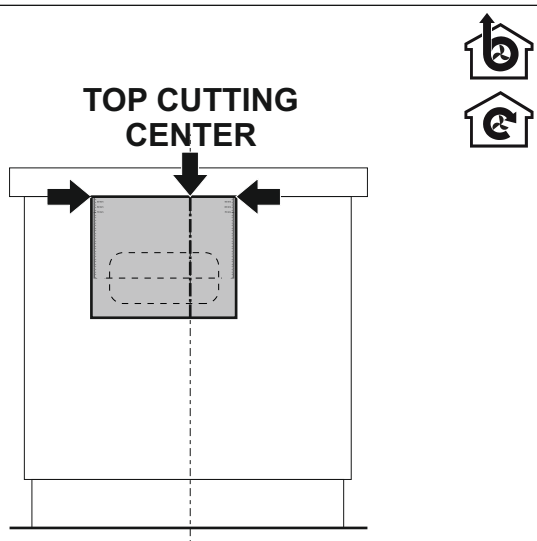

4

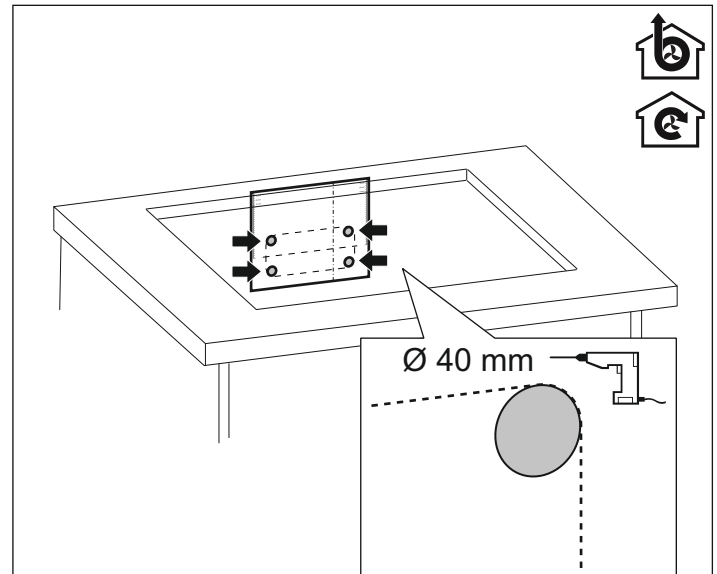

5

